

| DASH NO. RANGE | "D" DIA. RANGE | "E" DIMENSION | "G" GAP | "R" RADIUS | "T" GAUGE |
|----------------|-------------------|---------------|---------|------------|-----------|
| -2L THRU -8L | 1/8" TO 1/2" | "D"/2 + .505 | .06 | .08 | .020 |
| -2 THRU -8 | 1/8" TO 1/2" | | | | .031 |
| -9 THRU -12 | 9/16" TO 3/4" | "D"/2 + .535 | .09 | .11 | .050 |
| -13 THRU -23 | 13/16" TO 1-7/16" | | | | .062 |
| -24 THRU -32 | 1-1/2" TO 2" | "D"/2 + .530 | .13 | .11 | .050 |
| -33 THRU -66 | 2-1/16" TO 4-1/8" | | | | .062 |
| -33L THRU -66L | | | | | |

MATERIAL & FINISH CODES:

METAL: "NO CODE" 1008/1020 LOW CARBON STEEL PER ASTM A 1008, ASTM A 109, QQ-S-698
 FINISH: ZINC PLATE GOLD PER ASTM B 633, Fe/Zn 8, TY. II
 "D" 2024-T42 ALUMINUM ALLOY PER AMS-QQ-A-250/5
 FINISH: NONE
 "DK" 5052-H32 1/4 HARD ALUMINUM PER AMS-QQ-A-250/8
 FINISH: NONE ①
 "SS" 304/321 STAINLESS STEEL PER AMS 5513/AMS 5510
 FINISH: NONE
 "P" 17-7PH CORROSION RESISTANT STEEL PER AMS5528
 HEAT TREAT TO TH1100 CONDITION PER AMS2759/3 AFTER FORMING
 FINISH: PASSIVATE PER AMS2700 & BAKE PER AMS2759/9

CUSHION: "G" GENERAL PURPOSE EPDM PER SAE J200 M3 BA 710 C12
 COLOR: BLACK
 "H" GENERAL PURPOSE SILICONE PER AMS 3303 WITH 100 PSI MIN. TEAR
 COLOR: RED/ORANGE
 "N" GENERAL PURPOSE NEOPRENE PER AMS 3209
 COLOR : BLACK
 "T" TEFLON SKIVED PER AMS 3652
 COLOR: WHITE

EXAMPLE OF PART CALLOUT:

1" DIA., .050 THK., ALUM. CLAMP W/ EPDM CUSHION

S520 D G 16 L
 LIGHT WEIGHT METAL OPTION (SEE CHART)
 DIA "D" IN 1/16" INCREMENTS
 CUSHION CODE
 METAL CODE (OMIT FOR "NO CODE")
 BASIC DRAWING NUMBER

NOTES:

- ① CAUSTIC ETCH TO CLEAN AS NEEDED.
- 2) CLAMPS FURNISHED IN THE NORMAL OPEN (SPRINGBACK) CONDITION.
- 3) INSPECT PER MIL-C-8603 CLOSURE TEST.



S520

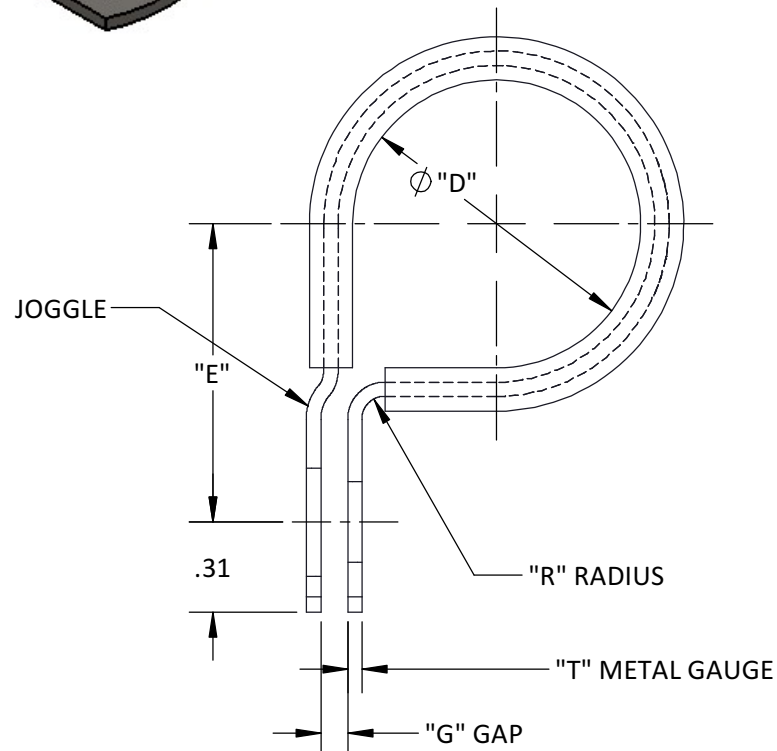

STEEL STAMP "UMPCO" & PART NUMBER

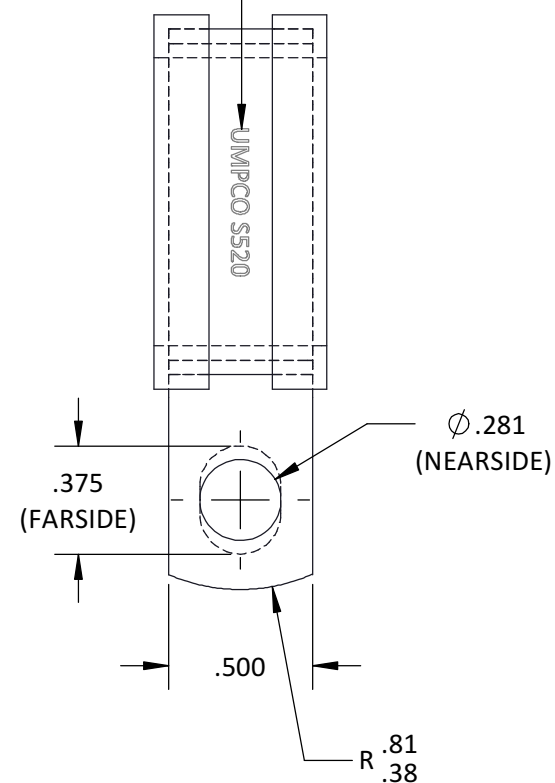

SHEET 1 OF 1

| | | | | | | | |
|--|---|-----|-------|--|---------|--------------------------|-------------|
| REFERENCES: | | | | | | | |
| LIMITS ON DIMENSIONS UNLESS OTHERWISE SPECIFIED: | ANGULAR: | X | ± 5° |  UMPCO . INC. 7100 LAMPSON AVE. P.O. BOX 5158 GARDEN GROVE, CA. 92846 | | FSCM/CAGE CODE No. 18076 | |
| | DECIMAL: | .XX | ± .03 | | | KEL | RPD |
| GENERAL MACHINE FINISHES EXCEPT AS NOTED: | PROPRIETARY AND CONFIDENTIAL THE INFORMATION CONTAINED IN THIS DRAWING IS THE SOLE PROPERTY OF UMPCO, INC. ANY REPRODUCTION IN PART OR AS A WHOLE WITHOUT THE WRITTEN PERMISSION OF UMPCO, INC IS PROHIBITED. | | | 03/12/82 | | 03/02/05 | 03/02/95 |
| | INTERPRET GEOMETRIC TOLERANCING PER: ASME-Y14.5M | | | DRAWN | CHECKED | ENGR | |
| REMOVE ALL BURRS AND BREAK SHARP EDGES .010 MAX | ACT. WGHT. | - | | CLAMP, LOOP-TYPE, SUPPORT, CUSHIONED, FOR 1/4" MOUNTING BOLT | | SIZE | SCALE: NONE |
| | CALC. WGHT. | - | | PART AND/OR ASSEMBLY DESCRIPTION | | B | S520 |
| | | | | | | PRINT NUMBER | |

1

2

3

4

5

6

7

8